

GB

Operating, maintenance manual

TRUCK MIXER

DB 1200

HYDROSTATIC

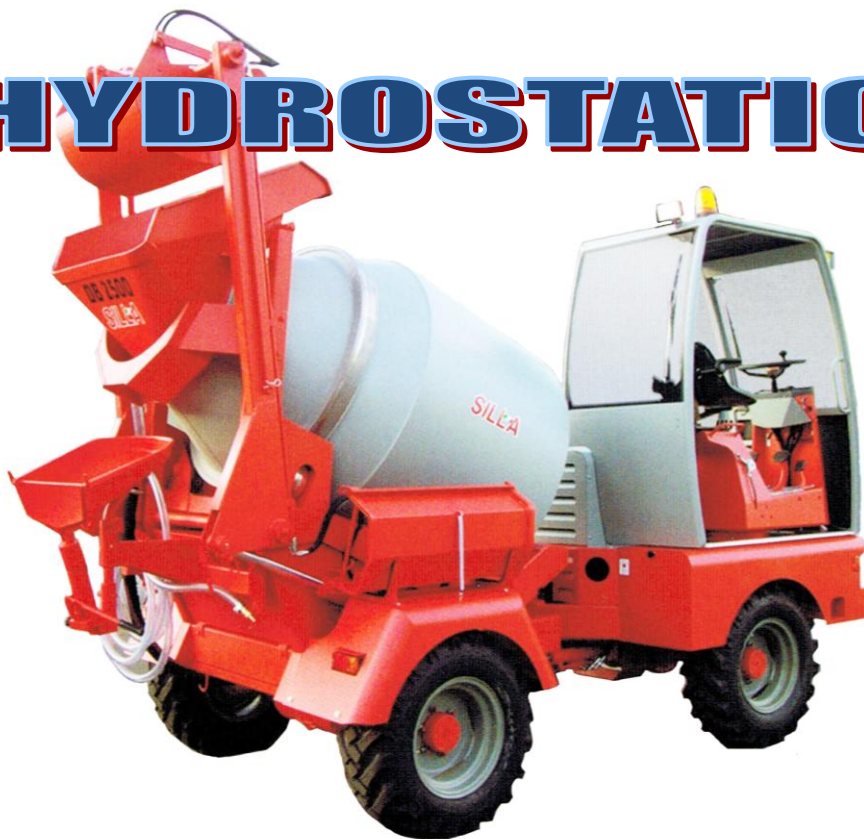

SILCA

Macchine Edili e Stradali s.r.l.
Via S, Gimignano n°96 Poggibonsi (SI) – Italy
e-mail : info@sillaitaly.com web site: www.sillaitaly.com

REV. 01 Date January 28, 2015

	INDEX	Page
1	INTRODUCTION	2
2	MARKING	2
3	GENERAL PRECAUTIONS	3
4	CHARACTERISTICS	3
4.1	Description of the machine	3
4.2	Dimensions and technical characteristics	4
4.3	Safety instructions	4
5	INSTALLATION/NEW SITE	5
5.1	Transport	5
5.2	Placing and how to leave the machine	5
5.3	Areas of respect and overall dimens.	5
5.4	Preparations before use	5
5.5	Safety first	5
5.6	Putting into operation	5
5.7	Training	6
6	ADJUSTMENTS	6
6.1	Adjusting the machine	6
6.2	Adjusting the parking brake	6
6.3	Adjusting the seat	6
7	CONTROL INSTRUMENTS	6
7.1	Warning lights	6
7.2	Controls	6
7.3	Water system	7
7.4	Electrical and hydraulic diagrams	7
7.4.1	Relay/fuse box	7
7.4.2	Hydraulic diagram	8
7.5	Operation and controls	9
7.5.1	Steering wheel	9
7.5.2	Starting switch	9
7.5.3	Hour meter	9
7.5.4	Rotary lamp switch	9
7.5.5	Warning lights switch	9

	INDEX	Page
7.5.6	Indicators dev.	9
7.5.7	Headlights/Horn switch	9
7.5.8	Accelerator pedal	9
7.5.9	Brake pedal	9
7.5.10	Parking brake lever	9
7.5.11	Drum lifting lever	9
7.5.12	Grab bucket arms drive lever	9
7.5.13	Grab bucket drive lever	9
7.5.14	Water pump lever	10
7.5.15	Drum rotation lever	10
7.5.16	Driver's seat rotation	10
7.6	Use of the machine	10
7.6.1	Starting the engine	10
7.6.2	Stopping the engine	10
7.6.3	Starting the mixer	10
7.6.4	Auto-loader	10
7.6.5	Water system	10
7.6.6	In action on the construction site	10
8	MAINTENANCE	10
8.1	Routine and extraordinary maintenance	11
8.1.2	Daily maintenance	11
8.1.3	Weekly maintenance	11
8.1.4	Maintenance to be performed every 15 days	11
8.1.5	Maintenance to be performed every 100 hours	11
8.1.6	Maintenance to be performed every 2000 hours	11
8.2	Corrective maintenance	11
8.2.1	Troubleshooting	11
8.3	Maintenance of hydraulic system	12
8.3.1	Check the brake pedal	12
8.3.2	Check the parking brake	12
8.3.3	Check the tires	12
8.3.4	Spare parts	12
9	DISMANTLING	12
9.1	Disassembling and dismantling	12
9.2	Disposal	12

1. INTRODUCTION

This manual is directed at the user and operator who will be responsible for the safe, efficient and trouble free operation of the machine. Read and understand this manual and always follow the safety precautions stated in the chapters General Precautions and Operation. Keep this manual handy for frequent reference and to pass on to new operators or owners. The machine is equipped with tested special safety devices and safety systems. SILLA cannot be held responsible for unauthorized modifications or procedures, replacements and/or all other modifications changing the use the machine has been designed and manufactured for.

Warranty: The mechanical and electrical products of the machine, which are not normal service items, have a one-year warranty starting from the date of the sale. The warranty does not cover the normal service items like tools, driving belts, liquids and oils. The defective or not properly working products will be replaced by the Technical Personnel of the Manufacturer of the machine, after the defective product has been proven to be defective. The warranty does not cover the products in case of modification, abuse, misuse, improper use, negligence or improper maintenance (routine and extraordinary maintenance) as shown by this I.M. This warranty is valid in the territory of the European Community. The consumer is the right holder according to the applicable national laws governing the sale of consumables and this warranty makes those rights unprejudiced.

2. MARKING

A label with the following machine identification data is installed on the machine:

- Name and address of the manufacturer and/or legal representative in Europe; - Machine type; - Serial or part number; - Year of construction; - Weight of the machine. - Max. rating; - Ready mixed product in litres; - Loading capacity.

For assistance and information or spare parts refer to:

SILLA *Macchine Edili e Stradali*

Via S.Gimignano , 96

53036 – POGGIBONSI (SI) - ITALY

Tel. ++39-0577 - 938051 Fax. ++39-0577 – 981609

E-mail: info@sillaitaly.com Web Site: www.sillaitaly.com

This Instruction Manual and all the enclosed documents are freehold property of the Company SILLA.

Reproduction (in any form or way inclusive recording and photocopy) in whole and/or part is forbidden without the written authorisation of the Company SILLA. In case this Instruction Manual should get lost or destroyed ask the Company SILLA for a complete copy.



Caution! Precautions and instructions to be strictly followed.

3. GENERAL PRECAUTIONS



The operating safety of the machine is only granted for the functions listed in this instruction manual.

SILLA cannot accept any responsibility, if the machine should be used for different uses than those listed in this manual or those, which do not comply with the operating instructions.

SILLA cannot accept any responsibility for safety, liability and performances of the machine, if the precautions and the instructions of this instruction manual, especially referred to: use, in the construction site and on the road (only for homologated vehicles), maintenance and dismantling are disregarded.

The operating safety is only guaranteed for the functions listed in this instruction manual.

SILLA cannot accept any responsibility, if the machine is used for other purposes than those stated in this manual and which do not comply with the operating instructions.

For all repairs, please refer to the After-Sales Service authorised by the supplier of the machine. The user of the machine is the only responsible for its good and safe operation, if the machine was not repaired or maintained by the specialized or authorised personnel.

For special maintenance and repairs use only original spare parts.

All these operations must be performed in a suitable location, with the machine turned OFF, taking care to remove the ignition key from the panel in order to avoid inappropriate starting (by other people) and with the parking brake applied.

All the operators using the machine shall be trained on its correct use, the warning devices, the behaviour and actions to maintain for the proper use of the machine, assuring either their personal or other's safety.

The machine is delivered with by the operator himself. Check and maintain these protection devices and the machine according to the maintenance schedule. The operator shall be cautious in using the machine when the drum and the bucket are moving and when approaching with his hands, and particularly:

DO NEVER TURN ON THE MACHINE WITHOUT THE PROTECTION SHIELDS;

DO NEVER REMOVE AND NEVER OPEN THE PROTECTION SHIELDS WHILE THE MACHINE IS RUNNING.

Ensure good lightening in the work area and around the machine, in order to avoid shady areas, dangerous dazzling and stroboscopic effects.

Before starting any work, check the work area for any unauthorised persons or obstacles.

The operator shall wear appropriate clothing: work gloves, protective helmet, safety shoes, and respiratory protection. Do not wear any jewellery or clothing that can get caught or distract from the operation of the machine.

Follow the safety instructions, in particular: Turn off the machine before opening or cleaning it; ensure no one can turn it on by accident; Use the protective equipment (work gloves, ear muffs, safety shoes, respiratory protection) during use, assembly and maintenance of the machine;

Be cautious in approaching all the moving parts. - Before starting work and turning on the machine, CHECK: - the work area (5 metres all around the machine) for any persons or obstacles.

Follow the safety instructions shown in chapter SAFETY PRECAUTIONS.



4. CHARACTERISTICS

4.1 Description of the machine

The truck mixers for the construction sites are designed, manufactured, tested and sold by the company Silla. These machines are designed for loading aggregate, mixing and transporting the concrete on construction sites.

The main feature of these machines is that they are very simple, strong and reliable. The peculiarity of the articulated frame and the permanent four-wheel drive allow it to operate on all types of terrains ensuring safety and reliability over time. The auto-loading arm with the grab bucket and the mixing drum, make the machine reliable. A quick check in the morning will give you a faithful and safe fellow worker all day. The driver's seat allows excellent visibility in any position, and the operator has full control of the controls and of the central diagnostic panel.

4.2 Overall dimensions:

Attention !!!! Concrete dosed at 350 kg/m³ (plastic consistency **S2**) concrete volume can vary according to the local granulate, grain size, porosity and percentage and humidity of sand.

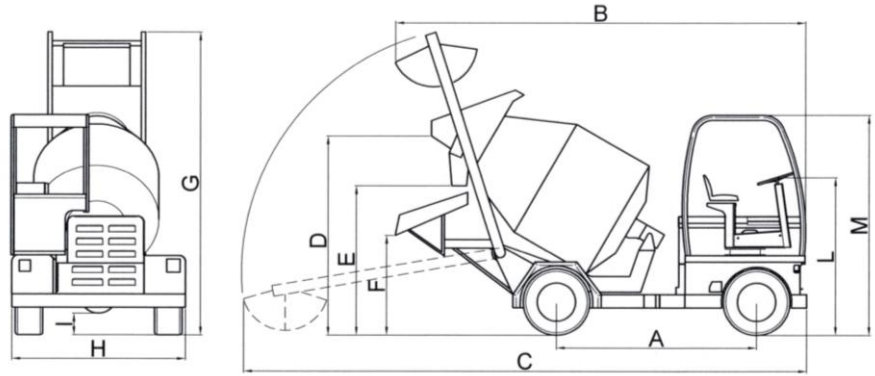

	DIMENSIONS	DB 1200
A	AXLE SPACING	1150
B	MINIMUM LENGTH	4230
C	MAX. LENGTH (WITH BUCKET ON THE GROUND)	5140
D	HOPPER HEIGHT	2065
E	CONVEYOR HEIGHT	1575
F	MAX. UNLOADING HEIGHT	1220
G	MAXIMUM HEIGHT	2970
H	MAXIMUM WIDTH	1550
I	MIN. HEIGHT FROM THE GROUND	245
L	STEERING WHEEL HEIGHT	2000
M	CABIN WHEL	2930

TECHNICAL CHARACTERISTICS	DB 1200
DRUM CAPACITY	1200Lt
MIX CAPACITY	1000Lt
GRAB BUCKET CAPACITY	90Lt
WATER RESERVOIR CAPACITY	170Lt
UNLADEN WEIGHT	2450Kg
MAXIMUM LOAD	2400Kg
DRIVE	Si
FORWARD/REVERSE SPEED	4/4 - 2/2
MAXIMUM SPEED	22 Km/h
GRADEABILITY AT FULL LOAD	30%
BRAKES	Brake drums
TYRES	11,5/80-15,3
MAX. ENGINE POWER	HP36/51
NUMBER OF CYLINDERS	¾
COOLING SYSTEM	Water
FUEL TANK CAPACITY	30Lt



4.3 SAFETY INSTRUCTIONS *Limits for use, space, life.*

The machine has been designed and built for use on open-air construction sites, according to the climate conditions with reference to the previous para.

(4.1). The machine must never be used in underground excavations, in areas at risk for explosions or fires, in closed places. The machine is designed and built for transporting concrete, sand, pebble gravel, cement, and water and for use on construction sites only. Ensure the areas of respect of the machine according to the range and the working areas involved. The machine has an attachment for towing. It's absolutely necessary for the proper performance of the machine and the security that the towing weight of **1500kg** is not exceeded. Otherwise SILLA is not responsible for any damage that may be caused. Never carry passengers. The machine is designed and built to carry only the operator / driver.

Working on hilly terrain can be dangerous.

Always operate in the low gears, do not move downhill with the engine off or with the transmission in neutral.

In condition of darkness pay attention to the work area and help yourself with all the lighting devices at your disposal.

It can be dangerous to leave the machine unattended in public places; place barriers around the work area, to keep away unskilled people. In case of maintenance, the raised arms of the bucket may fall suddenly; install a safety arm before working under the same. Diesel fuel is flammable.

Before connecting or disconnecting an electrical component, be sure to be familiar with the electrical system. An incorrect connection may cause injury and damage.

A battery with frozen electrolyte can explode if used or charged. Do not use the machine with frozen battery and do not recharge it. To prevent freezing, keep the battery fully charged.

The battery electrolyte is toxic and corrosive. Do not inhale gases from the battery. Keep the electrolyte away from clothing, skin, mouth and eyes. Wear safety goggles.

The machine is grounded to the negative pole of the battery.

Always ground the negative terminal of the battery. When connecting the battery the ground cable (-) must be connected last.

When disconnecting the battery the ground cable (-) must be disconnected first.

Always remember that the oil is a special waste and shall be disposed of according to the terms of the law.



CAUTION!!!!!! EVERY USE OF THE MACHINE DIFFERENT THAN THOSE STATED BY THE MANUFACTURER IN THIS INSTRUCTION MANUAL IS AN IMPROPER USE. THEREFORE, THE COMPANY SILLA CANNOT ACCEPT ANY RESPONSIBILITY, IF THE MACHINE SHOULD BE USED BY THE OPERATOR FOR DIFFERENT USES THAN THOSE LISTED IN THIS INSTRUCTION MANUAL OR THOSE NOT COMPLYING WITH THE OPERATING INSTRUCTIONS.

5. INSTALLATION/NEW CONSTRUCTION SITE



5.1 Transport **Caution!!** To unload them from the container, **provide a plane at the same level as the Container**, otherwise the machine may be damaged. The top or cab are disassembled, so you just have to mount them, connect the flashing lamp with the special connector, turn the battery cut-off switch to the ON position (because it was set to OFF during transport) and refuel.

The strength of the machines, their shape and size, are such to ensure transport and storage safely and without damage. The weight of the machines is shown on the CE plate; the weight being relevant, be very careful when loading and unloading. Make sure that the vehicle, which transports the truck mixer and the loading ramps, has adequate size and capacity. Always stop the wheels of the truck with wedges before loading or unloading the truck mixer.

Fix the ramps to the truck and drive the truck mixer on it with due caution. Switch off the engine, remove the ignition key, pull the parking brake and insert the battery cut-off switch. Remove the ramps, fix the wheels of the truck mixer with wedges, and tie the machine to the means of transport. The truck mixer has no specific points of anchorage; therefore tie the frame with straps. The machine is delivered with the following accessories:

- 1 Manual for use, maintenance and spare parts;
- 1 Instruction manual of Engine Manufacturer;
- 1 Hand pump equipped for greasing;
- 1 Socket wrench for wheel assembly;



It is recommended to take all precautions during loading-unloading and transport, in order to avoid danger and damage to people and machine. The loading and transport devices must be designed and approved in accordance to the weight to be supported. Never lift the machine, it is too dangerous.

Follow the safety instructions shown in chapter SAFETY PRECAUTIONS.



5.2 Placing and how to leave the machine The machine must be placed / parked in a flat area of the construction site, where it can be: **Covered – Washed – Stored – Upket.**

- Provide in the area of placement of the machine:
- Power supply;
 - Lighting;
 - Water supply.

- Ensure an area of respect around the machine of at least 2 meters.



The machine must be placed in areas without gas, explosive materials and/or highly flammable materials. Follow the safety instructions shown in chapter SAFETY PRECAUTIONS.

The use of the machine by unauthorized personnel is not allowed.



5.3 Areas of respect and dimensions The working space needed for correct use and proper maintenance is at least 5 metres, that is the area of respect around the machine, within which you must pay close attention to both people and things, thus avoiding obstacles while using the machine.

Working debris may make the driver's seat slippery. Use personal protective equipment such as safety shoes and provide periodic cleaning of the floor.



Warning: the use of chemicals, shampoos or products to clean the machine can be harmful to a person's health. Carefully read the instructions of the product used. They can also modify the quality of the painting of the truck mixer and damage its hydraulic parts, then use carefully.



5.4 Preparations before use. Use protective gloves when preparing and putting into use.

Check levels of engine oil, clutch and brake fluid, hydraulic oil. Check refuelling so as to avoid having to stop work. Check tire pressure and their condition of use.

Clean shoes and steps from mud and grease before getting on the machine. Be sure of perfect visibility from the driver's seat and that the warning labels and the various accident prevention devices are clearly visible. Wear ear protections.

5.5 Safety first. All machines can be dangerous. When a truck mixer is properly used and maintained, it is an extremely safe machine. If the machine is used incorrectly, it can be rather dangerous. Both in this manual and on the machine you will find the warnings, indicating all the potential dangers and how to avoid them. If you have any doubts, ask your dealer or your direct manager for explanations. Do not work with the machine until you are able to control it. Do not start any work until you are certain of your and other's safety. You may run into accidents if you perform unfamiliar operations without prior testing, which must be carried out in free areas, away from other people and on level ground.



Follow the safety instructions shown in chapter 4.3 SAFETY PRECAUTIONS.



5.6 Putting into operation Before putting the machine into operation, especially the very first time, or when it is installed on a new work place, carry out the following preliminary checks and keep in mind the following technical warnings and tips:

- Check oil level;
- Check tire pressure and condition of use;
- Check the area of respect and the workspaces;
- Check that the protections are set correctly;
- Check that the indications and warning signs are placed on the machine and are easily visible.

- Carry out a general test of all mechanical and electrical controls of the machine, so as to check their accuracy, efficiency and operation;

- Check levels of engine oil, clutch and brake fluid, and hydraulic fluid;
- Check refuelling so as to avoid having to stop work.



5.7 Training Before using the machine, read carefully this instruction manual and understand how to use the machine in a safe way.

6. ADJUSTMENTS

6.1 Adjusting the machine At first operation on the construction site, the machine does not need any adjustments. Verify only the points defined in: 5.4 Preparations before use.



Never carry out adjustments with the machine running/operating. Follow the safety instructions shown in chapter SAFETY PRECAUTIONS. Every single adjustment and/or modification of the safety/work parameters set on the machine, which has not been authorised by the technical personnel of the company SILLA or which is not stated in this instruction manual, may influence the quality of the product and injure the operator's health. The company SILLA declines any responsibility for liability, performances and safety of the machine in case of modification/alteration of the machine and of the relevant operation/safety parameters.

6.2 Adjusting the parking brake

Brake adjustment is carried out directly on the brake lever. By turning the knob of the brake lever you can adjust by loosening or tightening. To get a proper adjustment, the stress on the brake lever must be of 10Kg.



Avoid "playing" with the brake knob, you may modify it and when necessary it will not work properly.

6.3 Adjusting the seat

Forward-backward adjustment.

The seat can be moved back and forth to adjust the distance of the pedals: the operator must be able to press the pedals while keeping his back resting against the seat.

To adjust the seat position, act on the indicated lever and slide the seat in the ideal position.

Make sure that the seat is locked.

7. CONTROL INSTRUMENTS

7.1 Warning lights

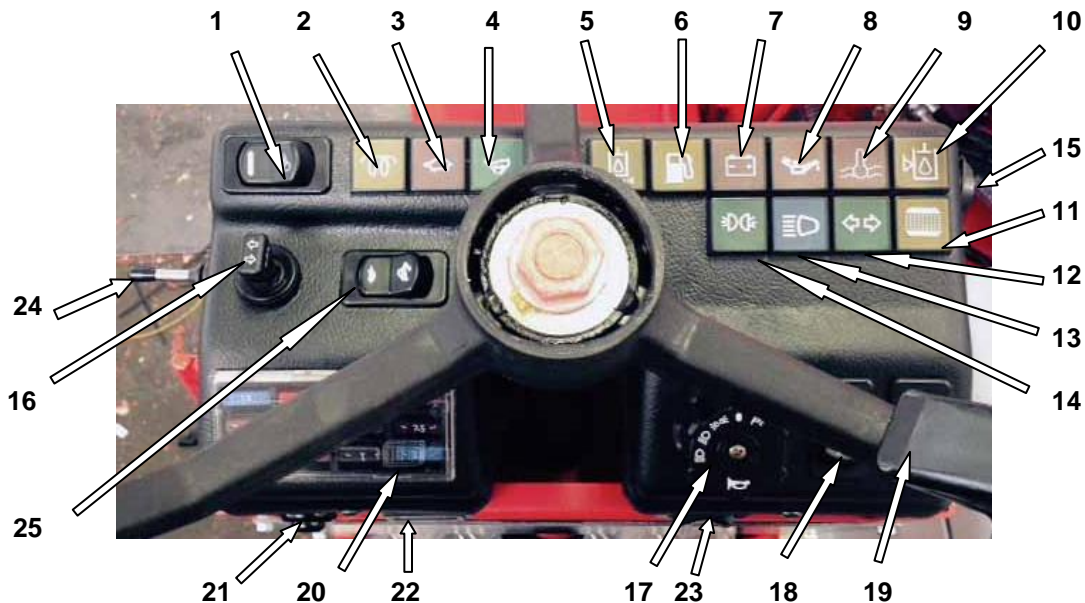

- | | | | |
|-------------------------------------|----------------------------------|--|--------------------------------|
| 1 - Switch working light | 2 - Preheater indicator | 3 - Spy Creep | 4 - Spy gear fast |
| 5 - Spia intasamento olio idraulico | 6 - Low fuel warning light | 7 - Spy charge generator | 8 - Oil level warning |
| 9 - Water temperature indicator | 10 - Spia livello olio idraulico | 11 - Light air filter | 12- Indicators light direction |
| 13- Light headlights | 14 - Spy position lights | 15- Ignition key | 16- Switch arrows |
| 17- Light switches and Claxson | 18- Switch around lighthouse | 19 - Emergency Lights | 20 - Fuse box |
| 21 - Pulsante Avviamento motore | 22 - Hour meter | 23 - Commutator switching steering wheel | |
| 24 - Comando Avanti Indietro | 25 - Interruttore Lento Veloce | | |

7.2 Fuse box

- 1- +30 15A 2- +30 Battery 10A 3- +30 Power Leds 4- +15 Starter key
 5- Power lights position 3A 6- Power lights position 3A
 7- Luci anabbaglianti 7,5A 8- Luci abbaglianti 7.5A 9- Claxson and horn 3A
 10- +15 Starter key 7,5A 11- +15 Alternator and consent backtrack 1A
 12- Flashing 15A

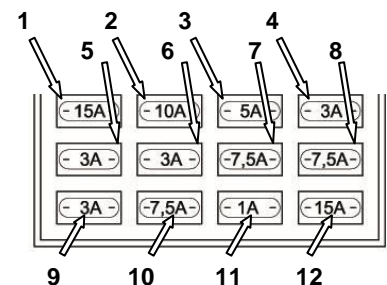

7.3 Water system

On first use you have to fill the tank: lever 1 in position "A". lever 2 in position "A".
 When the tank is full: lever 1 in position "B", lever 2 in position "B", lever 3 in position "B" if you want to put water in the drum, lever 3 in position "A" if you want to wash with the water jet pipe.

Level 1 Position	Function	Level 2 Position	Function	Level 3 Position	Function
A	Suction from the well	A	Flow to the tank	A	Water jet pipe
B	Suction from the tank	B	Flow to the drum	B	Drum

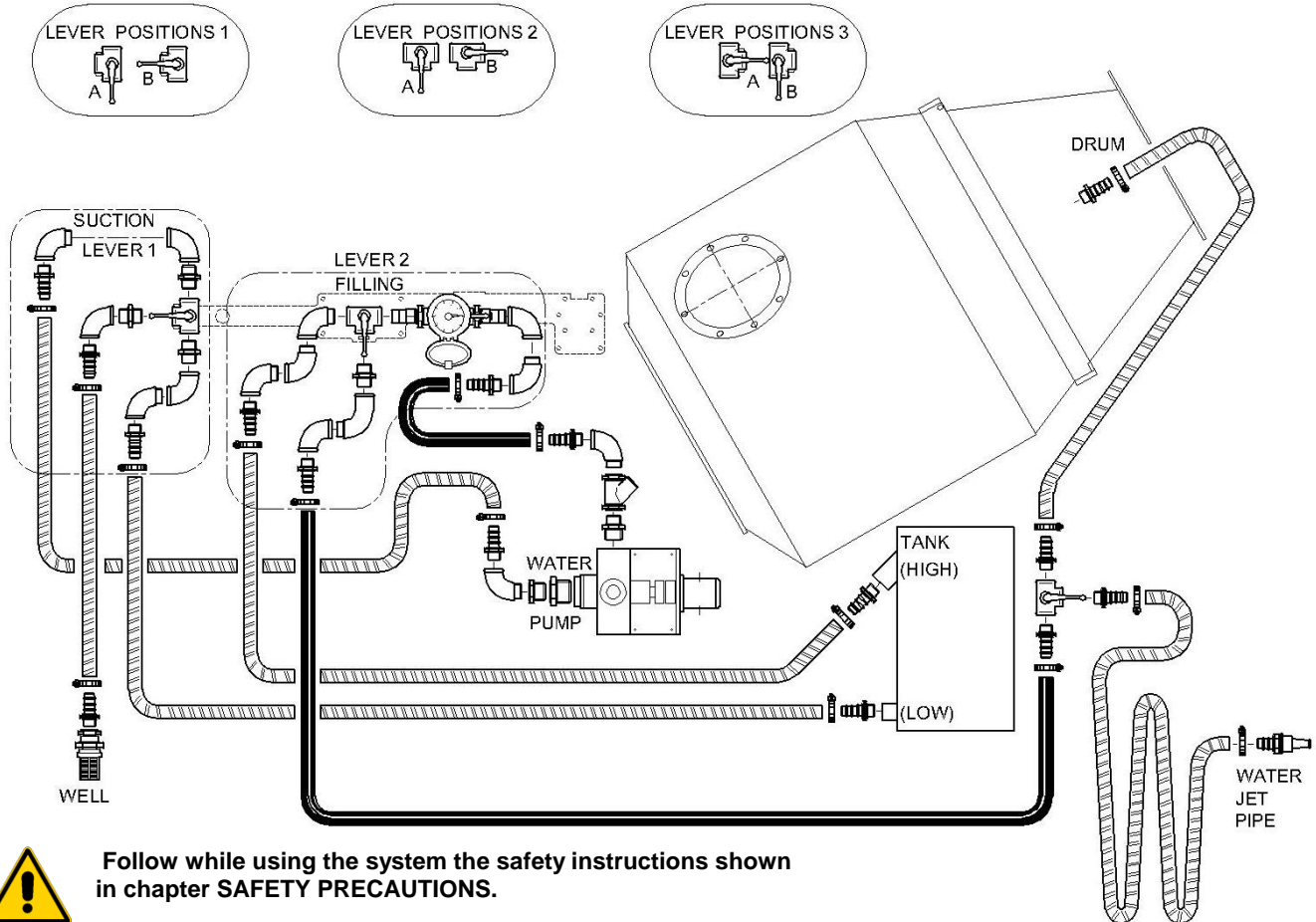

Follow while using the system the safety instructions shown in chapter SAFETY PRECAUTIONS.

7.4 Electrical and hydraulic diagrams

7.4.1 Relay/fuse box

Vedi Allegati

7.4.2 Hydraulic diagram

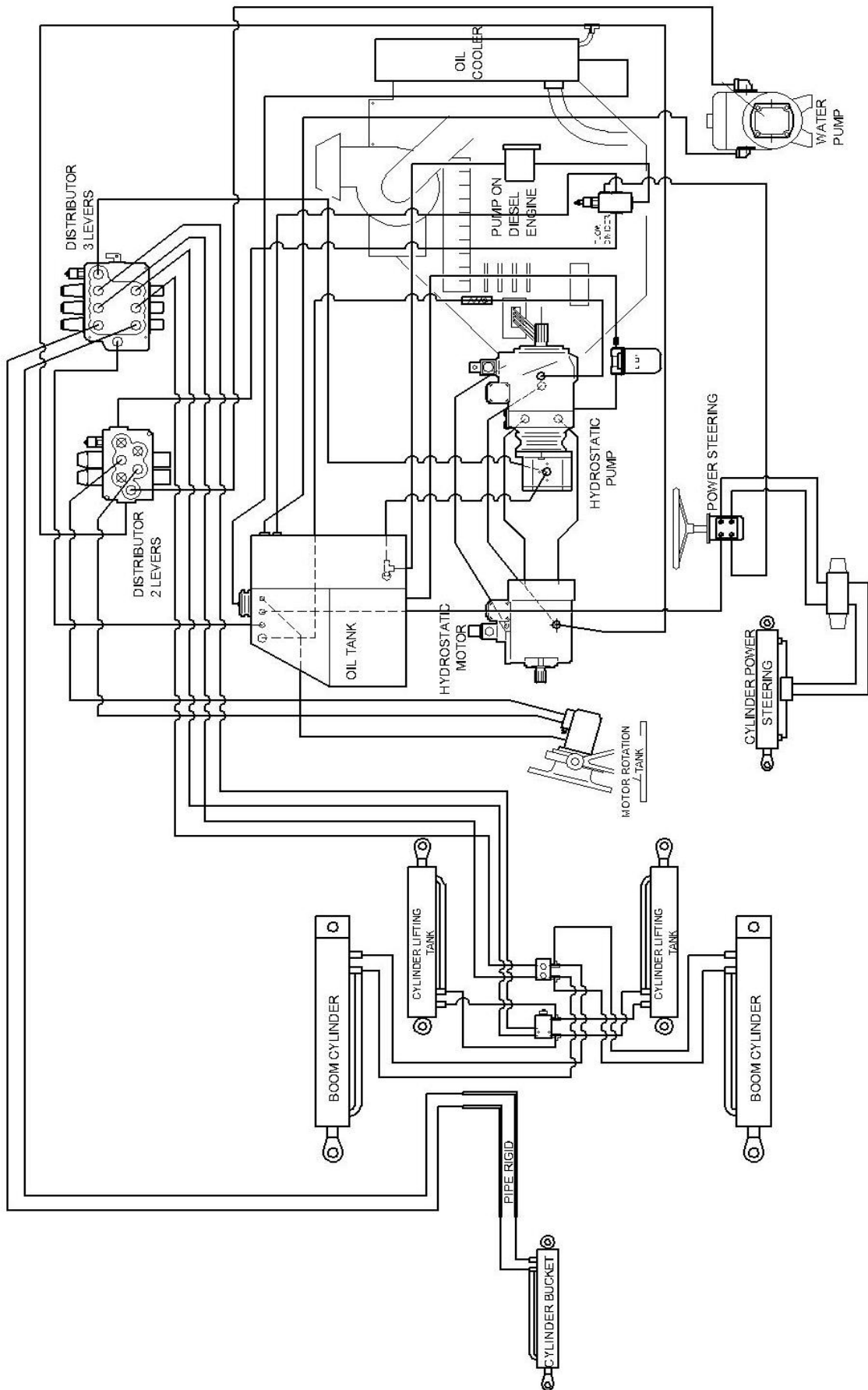

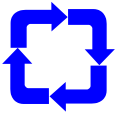

7.5 Operation and controls

- **7.5.1 Steering wheel**

Turn the steering wheel in the desired direction. Power-assisted steering system powered by means of hydraulic pump and acting with hydraulic jack on the front half-frame.

All duties are hydraulic: transmission, steering, braking and all movements, therefore: Do not use the machine with the engine off !!!!



- **7.5.2 Starting switch**

Position "0" OFF engine stop: Engine stop position.

Before stopping the machine, make sure that it is stopped and the parking brake set.

Position "I" ON. In this position the switch connects the battery to all the electric circuits with the exception of the headlights and the warning lights. The lights and the emergency circuit are always live. The ignition key automatically returns to that position when it is released from the position "II" and "III".

Position "II" Preheating.

When starting the machine in cold climates, keep the key in this position to heat the glow pugs. The preheating position should not be maintained for more than 15 seconds.

Position "III" Starting. Activates the engine starter and the engine runs.

Do not activate the engine starter for more than 20 seconds at a time. After each starting attempt, let cool for at least 2 minutes then repeat the operations from position "II". Do not use the starter with voltages greater than 14Volt.



Do not use the starter to move the vehicle.

- **7.5.3 Hour meter** Indicates the working hours of the machine with the key inserted, check it to determine the lubrication and maintenance program.
- **7.5.4 Rotation lamp switch** Enables/Disables rotating lamp.
- **7.5.5 Warning lights switch** Enables/Disables warning lights.
- **7.5.6 Indicators device** Activates the direction indicators.

- **7.5.7 Headlights/Horn switch**

Activates the headlights, low beams at first click and high beams at the second click. By pressing it in any position (zero, first click or second click) it activates the klaxon.

- **7.5.8 Accelerator pedal**

Press the accelerator pedal to increase the motor speed, release it to decrease.

Use the accelerator pedal with the upmost attention. It's not a racing car!!!

- **7.5.9 Brake pedal**

Press the brake pedal to slow down or stop the vehicle.

The service brake acts hydraulically by means of pump on the brakes.

The stop lights must light up when the brakes are used.

Use the machine only if both stop lights are working properly.

- **7.5.10 Parking brake lever**

To set the parking brake, pull the lever upwards. To release push it downwards.

Operate the lever to set the parking brake whenever you leave the driver's seat.

Never start with the parking brake set.

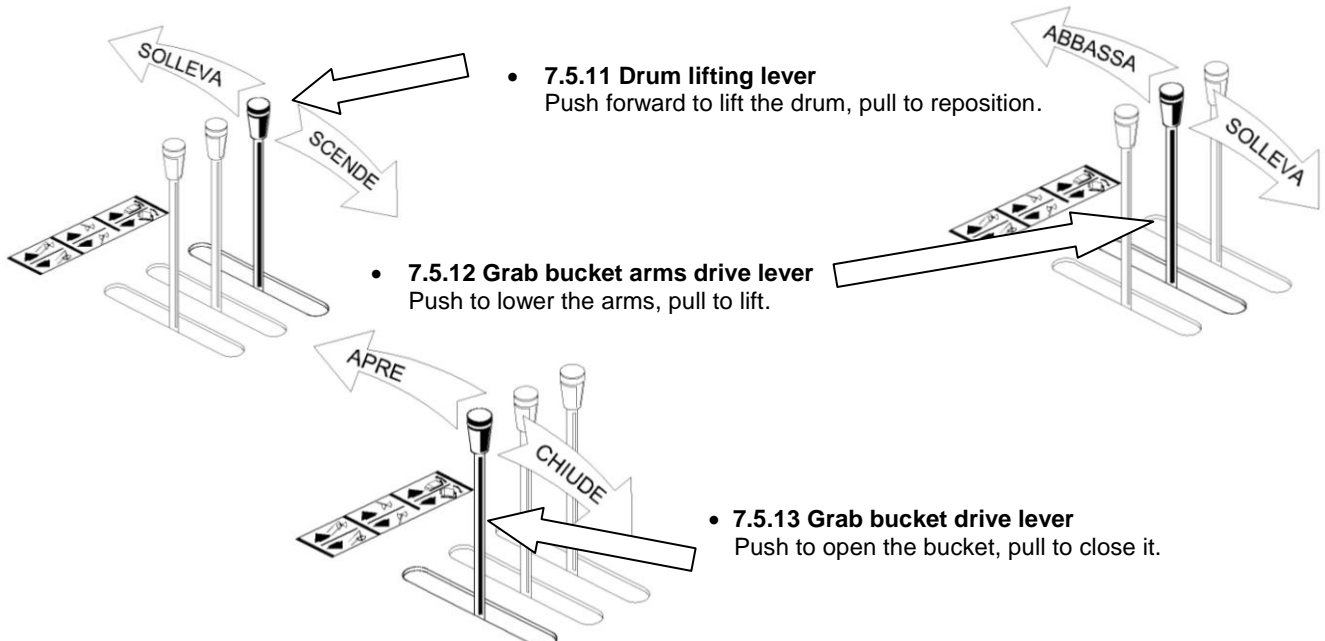

- **7.5.14 Water pump lever**

Pushing the lever it starts the water pump that stays in place until switching off by pulling the lever.
(see diagram 7.3 Water system).



- **7.5.15 Drum rotation lever**

Pushing the lever the drum turns in the "discharge" direction, pulling the lever the drum turns in the "mixing" direction.

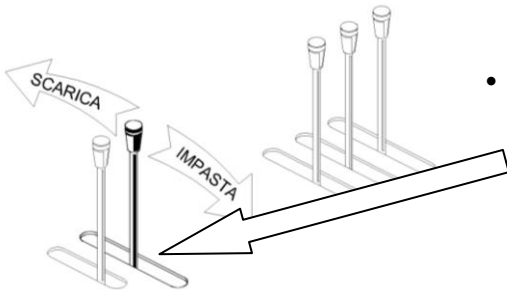

ALL THE MAINTENANCE OPERATIONS AND CHECKS MUST BE CARRIED OUT WITH THE MACHINE TURNED OFF,

PARKING BRAKE SET.

Always keep the machine switched off when it is not in use.

Always perform a test of all the controls and check that everything works properly .
Make sure that in the area of respect and work there are no people or objects large enough to compromise the security.

7.5.17 Driver's seat rotation The driver's seat is turned in the direction of work, in order to check the drum operations, the arms and the grab bucket, by using the lever under the seat. When pushing it downwards and turning the driver's seat by hand up to the 180° click, you get the position you want, but **be careful** when using button n. 23 "driving switch", press it whenever you change the direction of the driver's seat, otherwise the steering will work in reverse. Repeat the same operations for driving the vehicle on the site.

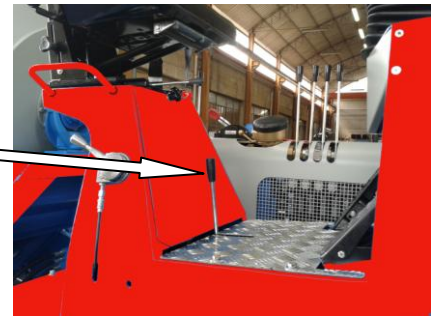

- **7.6 Use of the machine**

7.6.1 Starting the engine - Make sure that the parking brake is set. - Check the level of oil in the pan. - Make sure that there is sufficient fuel in the tank for the work to be performed. - Check level of hydraulic oil - Accelerate to about 3/4 of the run and engage the starter.

Caution! When the engine is running **do not** disconnect the contacts of the battery, to avoid burning of the capacitor.

7.6.2 Stopping the engine

Reset the throttle control by hand. Activate the stopping device.

7.6.3 Starting the mixer For mixing, the drum seen from the driver's seat, must rotate counter-clockwise.

- When you want to unload, stop the mixing operation, lift the drum and start clockwise rotation of the drum;
- The starting operations and reverse rotation of the drum must be performed with the engine idling.

CAUTION! At the end of each working cycle, wash the inside of the drum entering a shovelful of gravel, in order to avoid the formation of incrustations of concrete.

7.6.4 Auto-loader - Open the grab bucket, place the bucket on the heap with the machine stopped, close the bucket and lift the arms to unload the material inside the hopper. - Move the machine only when the bucket is lifted from the ground

7.6.5 Water system - When there is danger of frost, drain all water from the system, including the pump

- For the various manoeuvres see "Operating scheme - water system" (7.3) - Do not run the water pump dry.



The machine is the exclusive responsibility of the operator, which is the only one authorized to manoeuvre it.

Special precautions: Do not carry people; **Do not** turn the drum with hardened concrete;

Do not drive with the drum raised or with the seat turned towards the drum; **Do not** abruptly reverse the direction of rotation of the drum; **Do not** lower the shovel when the extension is inserted; **Do not** insist on the control levers when their cylinders have attained the end of the stroke; **Do not** abruptly brake or swerve at high speed; **Do not** tolerate the presence of others within the range of the machine;

7.6.6 In action on the construction site. Lift the drum (for unloading) only on firm level ground.

On sloping terrain, do not place the machine next to the slope and do not unload in that position, because you are likely to tip over. Maintain, on steep slopes, the opening of the full-loaded drum always facing upstream. Start the inversion of the rotation of the drum only with the engine idling. Every time you leave always leave the machine safely, that is with the bucket on the ground, the drum lowered, the motor stopped and the ignition key removed, the handbrake set. Drive always with the drum behind the driver's seat.

SAFETY STANDARDS The driver of public works vehicles, in order to work profitably and safely, must have experience of mechanical means, know the various commands, the operational characteristics as well as the stability of the machine entrusted to him and possess an adequate sense of prudence and skill. A risky manoeuvre, out of laziness or to save a few minutes, could also result in a serious accident with subsequent stopping of the whole construction site.



Never tow the truck mixer on the road. Use appropriate means of transport.



8. MAINTENANCE The machine does not require any particular maintenance work.

The technical solutions and the components installed on the machine reduce the maintenance works at the minimum. However, we recommend to carry out a series of operations, which aim at ensuring safety, liability and efficiency of the machine for a long period of time.

During maintenance Work on the machine only after having placed/parked it in the area defined in point 5.2 Placing and how to leave the machine. In the event of mechanical or electrical problems, contact the authorized personnel. If the machine is out of service due to equipment failure, maintenance or repair, place a special sign to highlight this status and remove the ignition key. Always use personal protective equipment during repair and replacement of the machine parts.

Electrical work must be performed only by authorized personnel. Works on the engine must be performed only by authorized and skilled personnel. Do not place hands, arms or body parts near the handling and transmission area. Use a suitable device to remove debris (brush, wooden piece, etc.): **never use your hands!** Regular maintenance of the mechanical and electrical machine parts extends the life of the machine, ensures best performances and is an important safety factor.

8.1 Routine and extraordinary maintenance In the run-in period (50 hours). Do not force the engine and avoid intensely exploiting the machine performances. Clean the hydraulic oil drain filter after the first 20 hours. Check for leaks of hydraulic oil, brake oil, clutch oil, lubricants of various mechanical assemblies. Check tightness of all the bolts, in particular the fixing of the wheel rims, after the first 20 hours. Change the motor oil and perform the other operations provided by the manufacturer (see motor instruction booklet provided in the annex to this manual). Perform all daily, weekly, fortnightly and successive maintenance operations, as listed below.

8.1.2 Daily maintenance at the end of the work Eliminate any anomaly that had occurred.

Thoroughly clean the inside of the drum in order to avoid the formation of incrustations. With a strong jet of water wash the outside of the machine, to remove any residue. Grease all lubrication points, with the engine stopped and the drum in home position. Carefully check the tire condition. Check the condition of the brakes. Remove any debris from the driver's seat. **DO NOT wash with high pressure jets electrical parts and control elements.**



8.1.3 Weekly maintenance Check the oil level of the brakes, clutch oil, hydraulic oil with the engine stopped and

the

booms down. Check the fluid level of the battery. Check the belt tension of the blower fan.

Always remember that the oil is a special waste and must be disposed of in accordance with the law.

Wash the engine air filter and fill the pan up to level with oil. Check the condition of the drive belts.

8.1.4 Maintenance to be performed every 15 days Check free travel of the brake pedal, normal value is 20/25mm.

Check the travel of the handbrake lever, it must block with an effort not less than 10Kg.

Clean the hydraulic oil drain filter and the tank breather cap.

8.1.5 Maintenance to be performed every 100 hours of work. Replace the motor oil, see the instructions of the manufacturer. Replace the fuel filter cartridge. Replace the suction filter cartridges inside the hydraulic oil tank.

8.1.6 Maintenance to be performed every 2000 hours of work Replace the two suction filter cartridges inside the tank.

Replace hydraulic oil after cleaning the magnetic drain plug. Replace the oil exhaust filter.

Always remember that the oil is a special waste and must be disposed of in accordance with the law.



8.2 Corrective maintenance

Other corrective maintenance operations (extraordinary/repairs) must be

performed by authorized service personnel.

8.2.1 Troubleshooting

PART	PROBLEM	CAUSE			
Clutch	Does not disengage	Screw on release lever has to be adjusted Lack or loss of oil in the control device			
	Slips during engagement	Pump or control cylinder hardened			
Hydraulic brake	Insufficient	Lack or insufficient oil Air bubbles in the circuit Brake pump with worn seals Hose which swells under pressure Worn brake discs			
		They jam	Pump or cylinders jammed		
		Handbrake	Insufficient	Hand lever has to be adjusted Control linkage has to be adjusted Worn brake discs	
				Hydr. steering gear	Steering wheel is hardened
Drum	Rotates slowly if full				
		Rotates unevenly	Pressure relief valve has to be adjusted Suction filter cartridge is clogged Low oil level Obstructions in the suction pipe Worn pump Concrete is hardening, if drum full Heavy internal fouling, if drum empty		

PART	PROBLEM	CAUSE
Autoloader	Rises jerky or with difficulty	Pressure relief valve has to be adjusted
		Suction filter cartridge is clogged
		Low oil level
		Obstructions in the suction pipe
		Worn pump
Bucket	Closes without force	Pressure relief valve has to be adjusted
		Suction filter cartridge is clogged
		Low oil level
		Obstructions in the suction pipe
		Worn pump
Hydraulic oil	Overheats	Unsuitable oil quality
		Low oil level
		Pressure relief valves jammed
		Worn pumps
		Automatic return failure of distributor levers
		Excessive insistence on the levers by the operator, with the cylinders already at the stroke end
Water system	Does not pump water	Suction strainer clogged
		Entrained air in the suction pipe

For all other kinds of troubles, please refer to the After-Sales Dept. of the Company SILLA.



CAUTION !!!!! **SILLA** decline any responsibility in case the machine does not undergo maintenance as prescribed in this instruction manual and in case of use of spare parts and accessories other than original and not appropriate.

8.3 Maintenance of hydraulic system Protected against dust and infiltration, no special maintenance is required, unless verification of the level, but it requires a thorough cleaning of the oil. If you have to replace the two filter cartridges inside the tank, you need to drain the oil and remove the cover. Use only clean containers and fill the oil through funnel fitted with a filter. Any other work on the system must only be performed by qualified personnel and with appropriate equipment.

8.3.1 Check the brake pedal The travel of the pedal must be between 20 and 25mm.

8.3.2 Check the parking brake The control lever must block with an effort not less than 10 kg.

8.3.3 Check the tires Normal operating pressure 3,5Atm. When working on rough terrains it can be useful to ballast the tires by introducing the appropriate antifreeze liquid.

8.3.4 Spare parts When ordering spare parts, order the component from the supplier and/or manufacturer of the machine. Always mention the model of the machine, part number, type of machine, description of the desired component, quantity and the main features.

9. DISMANTLING

Should the machine not be used for a long time (e.g. holidays), carry out the following operations: Carefully clean the whole machine, remove dust, deposits and dirt. Wash the inner part of the drum. Remove the concrete deposits, but do not hurt the drum with hard objects like hammers, shovels, etc. Oil all the moving parts exposed to seizure and the mechanical components exposed to oxidation. Store the machine in a dry and ventilated place, or use a nylon covering.

9.1 Disassembling / dismantling

Before carrying out any dismantling or disassembling operation, disconnect the battery.

Disconnect all the electric and mechanical components;

Disassemble the driving parts, bridges, engine, and brakes.

Disassemble the hydraulic parts of distributor, hoses, cylinders, pump, and hydraulic steering gear.

Disconnect and disassemble all the other mechanical components and the wheels.

9.2 Disposal

The following are the materials the machine is made of:

Painted steel, aluminium and other metallic components. Plastic materials.

Oil-hydraulic materials. Cables, motors, battery and electric components.



Please dispose of these materials through specialised companies, in accordance with the laws in force.

11. WARRANTY REGISTRATION FORM

Machine type	Part number
--------------	-------------

IMPORTANT

This form must be filled out and stamped by the Dealer at the time of purchase of the machine. The Dealer or the buyer must send this form by registered mail to the After-Sales Dept. of the Company SILLA within 3 days from the purchase, attaching a copy of the delivery note or invoice.

The mailing of this form, with attached copy of the transport document or copy of the invoice, is an essential requirement to start warranty period.

The company SILLA does not recognize any warranty in case of failure to submit the required documents.

Date

Stamp and Signature of the Dealer

Messrs

SILLA *Macchine Edili e Stradali*

Via S.Gimignano , 96 - 53036 – POGGIBONSI (SI) – ITALY

11.1 WARRANTY CONDITIONS

Warranty means the repair and/or the replacement of those parts, which are proven to be defective in manufacture. The replacement of the whole machine is excluded.

The warranty is for the period of 1 year from the date of delivery to the user, that is to say the date written in the Warranty Registration Form.

The defective materials must be sent, free delivered, to our factory. After technical approval the material will be replaced and sent carriage forward.

The warranty expires in case of:

- modifications, repairs, alterations of the machine carried out by the buyer and not expressly authorised by SILLA.
- improper assembling or failure to use the machine according to the instructions of the instruction manual.
- The electric components are not covered by this warranty, because a wrong connection done by the user and/or line problems cause damage to these components.

Any repair under warranty will not interrupt the warranty period.

- **The dealers shall enter the serial number of the truck mixer, both in the delivery note and in the invoice.**

DATA DATE	MANUTENZIONE ENTRETIEN	SOSTITUZIONI REPLACEMENT	VERIFICA CONTROLE	NOME DENOMMER	FIRMA GRIFFE